

219ET024 SC

Reference	Item number	Qty	Description
1	1138 020 2601	1	Crankcase □ 2 - 6
2	9503 003 0355	1	Grooved ball bearing 16x35x11
3	9640 003 1560	1	Oil seal 15x22x4
4	0000 988 5211	1	Connector
5	0000 988 8600	2	Sleeve
6	1138 791 5902	1	Stop buffer
7	1138 020 2903	1	Crankcase (1-6) □ 9 - 13, 15 - 18, 25
8	1138 020 2905	1	Crankcase (7,8) □ 9 - 17, 19, 25
9	9523 003 4278	1	Grooved ball bearing 15x35x13
10	9640 003 1600	1	Oil seal 15x29.6x4
11	1138 791 5903	1	Stop buffer
12	1128 640 9100	1	Valve
13	0000 974 1200	1	Notched pin 2.6x8
14	0000 974 1200	1	Notched pin 2.6x8 (7,8)
15	1120 162 5200	1	Pin
16	1121 162 5205	1	Pin
17	1121 162 5200	1	Pin
18	1121 162 5200	1	Pin (1-6)
19	1125 162 5209	1	Pin (7,8)
20	1122 647 9400	1	Hose
21	1117 640 3800	1	Pickup body
22	1138 029 0500	1	Gasket
23	1138 030 0406	1	Crankshaft (25.2005)
24	9455 621 1520	1	Circlip 15x1
25	1138 664 2400	2	Collar screw
26	9022 341 1050	5	Spline screw IS-M5x25
27	0000 350 0525	1	Filler cap □ 28
28	9645 948 7734	1	O-ring 25x3.5
29	9022 346 0955	1	Spline screw IS-M5x9.4
	1138 007 1050	1	Set of gaskets □ 3, 10, 22

(1) MS 441, (2) MS 441-W, (3) MS 441-Z, (4) MS 441-VWZ, (5) MS 441-RVWZ, (6) MS 441-RZ, (7) MS 441 C-Q, (8) MS 441 C-Q Z

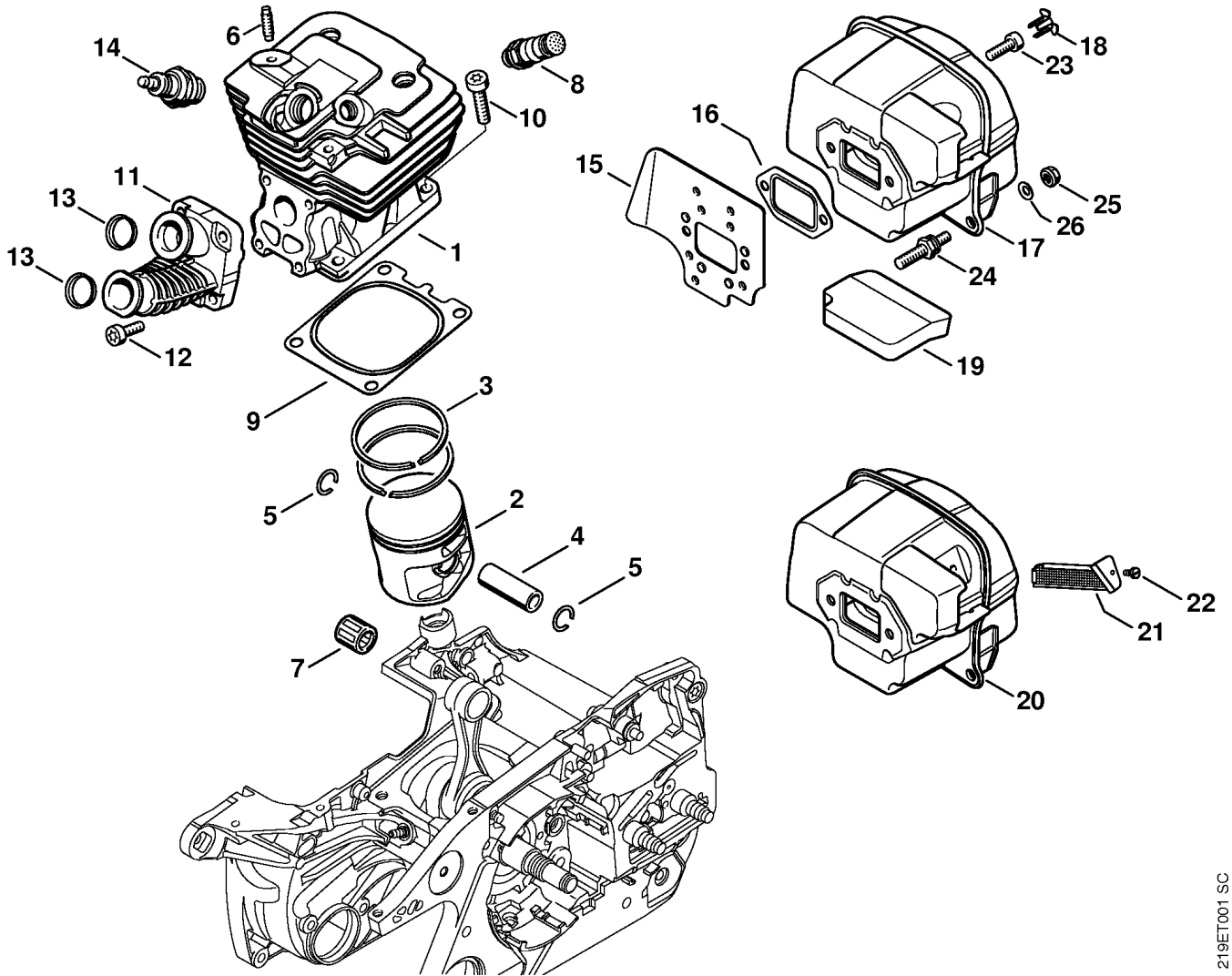

219ET001 SC

Reference	Item number	Qty	Description
1	1138 020 1201	1	Cylinder with piston Ø 50 mm □ 2 - 6
2	1138 030 2003	1	Piston Ø 50 mm □ 3 - 5
3	1128 034 3000	2	Piston ring Ø 50x1.2 mm
4	4224 034 1500	1	Piston pin 12x8x35
5	9463 650 1200	2	Snap ring 12x1
6	0000 953 0807	1	Stud M5
7	9512 003 3062	1	Needle cage 12x15x15
8	1135 020 9400	1	Decompression valve
9	1138 029 2300	1	Cylinder gasket
10	9022 371 1350	4	Spline screw IS-M6x25
11	1138 140 2501	1	Manifold
12	9022 341 0980	4	Spline screw IS-M5x16
13	1113 141 1805	2	Sleeve
14	1110 400 7005	1	Spark plug Bosch WSR 6 F
14	0000 400 7000	1	Spark plug NGK BPMR7A
15	1138 141 3200	1	Cooling plate
16	1125 149 0601	1	Muffler gasket
17	1138 140 0650	1	Muffler (1,2,7) □ 18
18	1135 145 9001	2	Plug
19	1138 140 9000	1	Insulating pad (1,2,7)
20	1138 140 0651	1	Muffler (3-6,8) USDA Cert. I.D. 1138/01 USA □ 18, 21, 22
21	1138 145 8600	1	Screen (3-6,8) USA
22	9099 021 0810	1	Self-tapping screw 4.2x9.5 (3-6,8) USA
23	9022 341 0982	2	Spline screw IS-M5x16
24	1138 148 0700	2	Collar screw
25	9220 260 0700	2	Hexagon nut M5
26	9331 630 0120	2	Conical spring washer 5
	1138 007 1050	1	Set of gaskets □ 9, 16

(1) MS 441, (2) MS 441-W, (3) MS 441-Z, (4) MS 441-VWZ, (5) MS 441-RVWZ, (6) MS 441-RZ, (7) MS 441 C-Q, (8) MS 441 C-Q Z

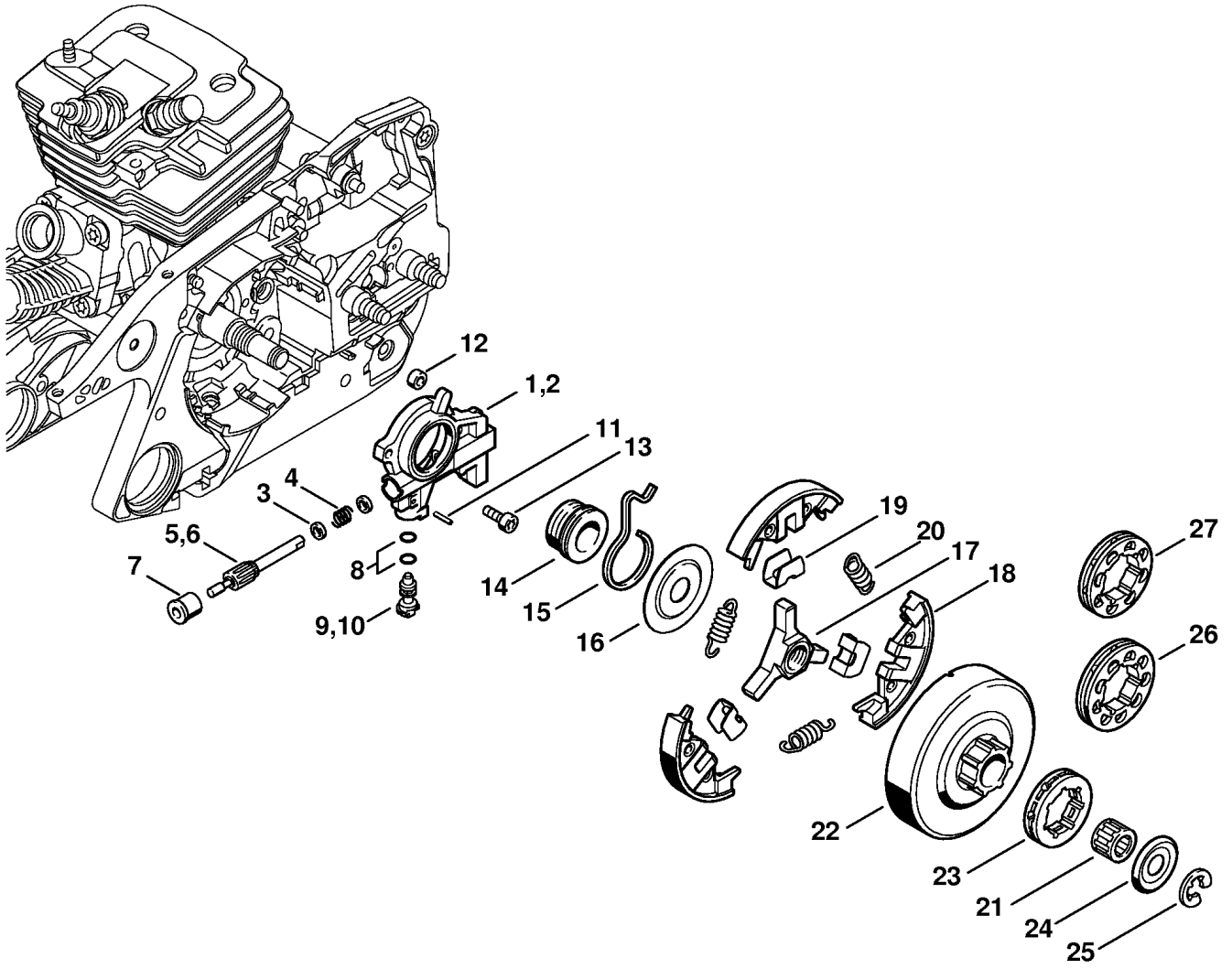

219ET002 SC

Reference	Item number	Qty	Description
1	1128 640 3206	1	Oil pump 0.8 (1-4,7,8) □ 3 - 5, 7 - 9, 11
2	1128 640 3250	1	Oil pump 1.1 (5,6) □ 3, 4, 6 - 8, 10, 11
3	0000 958 0518	2	Washer
4	0000 997 0615	1	Compression spring
5	1128 647 0606	1	Pump piston 0.8 (1-4,7,8)
6	1128 647 0602	1	Pump piston 1.1 (5,6)
7	1125 641 9400	1	Bearing bushing
8	9646 945 0160	2	O-ring 4x2
9	1128 647 4806	1	Control bolt (1-4,7,8)
10	1128 647 4803		Control bolt (5,6)
11	9380 620 1090	1	Roll pin 2x10
12	1122 649 5000	1	Sealing ring B4x2
13	9022 313 0660	2	Spline screw IS-M4x12
14	1128 640 7112	1	Worm □ 15
15	1128 647 2400	1	Spring
16	1122 162 1000	1	Cover washer 52 mm / 2 1/16"
	1138 160 2010	1	Clutch □ 17 - 20
17	1128 162 3202	1	Carrier
18	1138 162 0800	3	Clutch shoe
19	1128 162 3000	3	Retainer
20	0000 997 5816	3	Tension spring
21	9512 933 2380	1	Needle cage 10x16x12

(1) MS 441, (2) MS 441-W, (3) MS 441-Z, (4) MS 441-VWZ, (5) MS 441-RVWZ, (6) MS 441-RZ, (7) MS 441 C-Q, (8) MS 441 C-Q Z

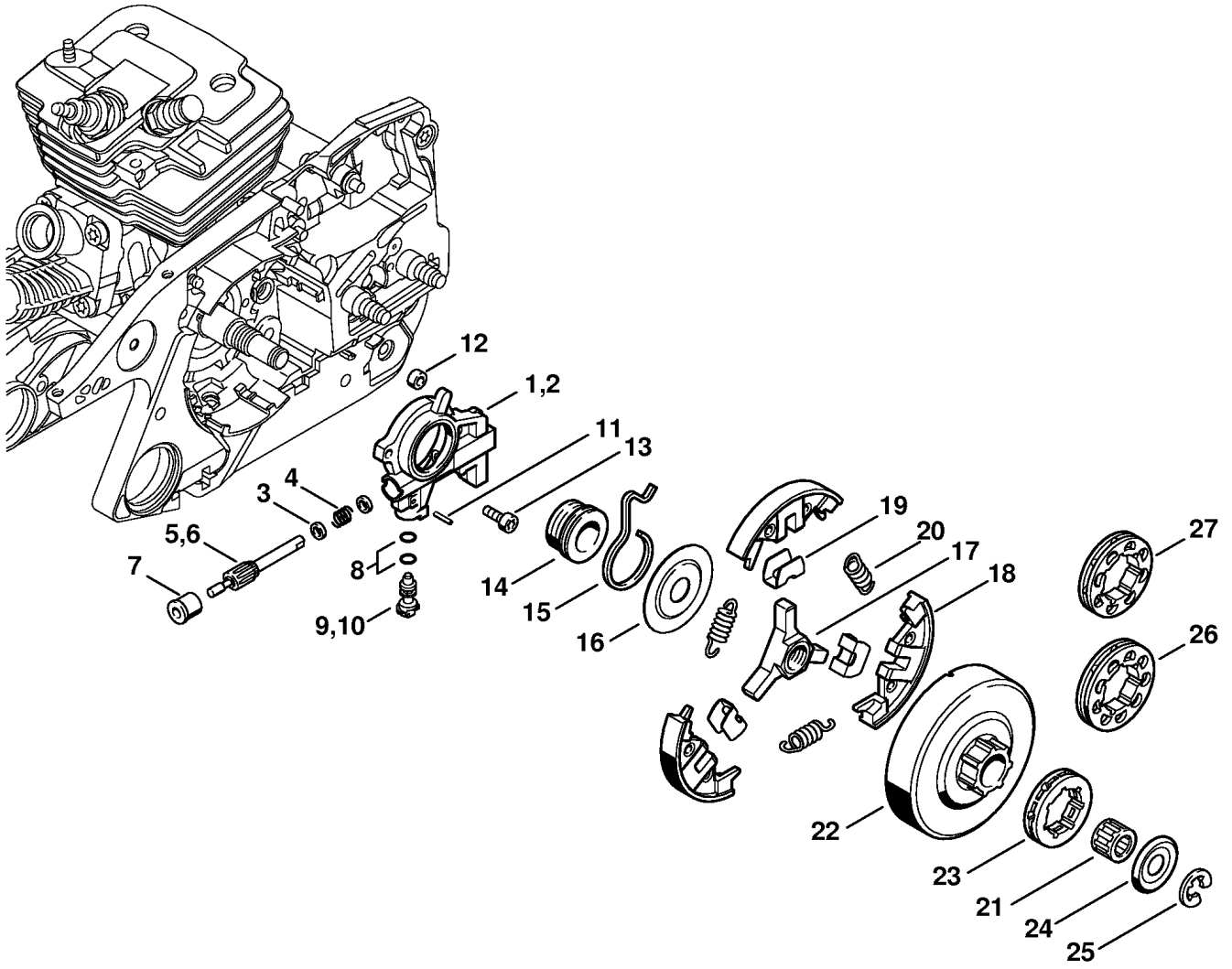

219ET002 SC

---

Reference	Item number	Qty	Description
	1128 007 1000	1	Rim sprocket kit 3/8" 7T (B) (1-6) □ 22 - 25
22		1	Clutch drum (D) (1-6)
23	0000 642 1223	1	Rim sprocket 3/8" 7T
24	0000 958 1032	1	Washer Ø 27 mm
25	9460 624 0801	1	E-clip 8x1.3
	1128 007 1011	1	Rim sprocket kit 0.325" 9T (B) (1-6) Skand. □ 22, 24, 25, 26
26	0000 642 1239	1	Rim sprocket 0.325" 9T (B) (1-6) Skand.
	1128 007 1001	1	Rim sprocket kit 3/8" 8T (B) (1-6) □ 22, 24, 25, 27
27	0000 642 1216	1	Rim sprocket 3/8" 8T (B) (1-6)

(1) MS 441, (2) MS 441-W, (3) MS 441-Z, (4) MS 441-VWZ, (5) MS 441-RVWZ, (6) MS 441-RZ, (7) MS 441 C-Q,  
(8) MS 441 C-Q Z



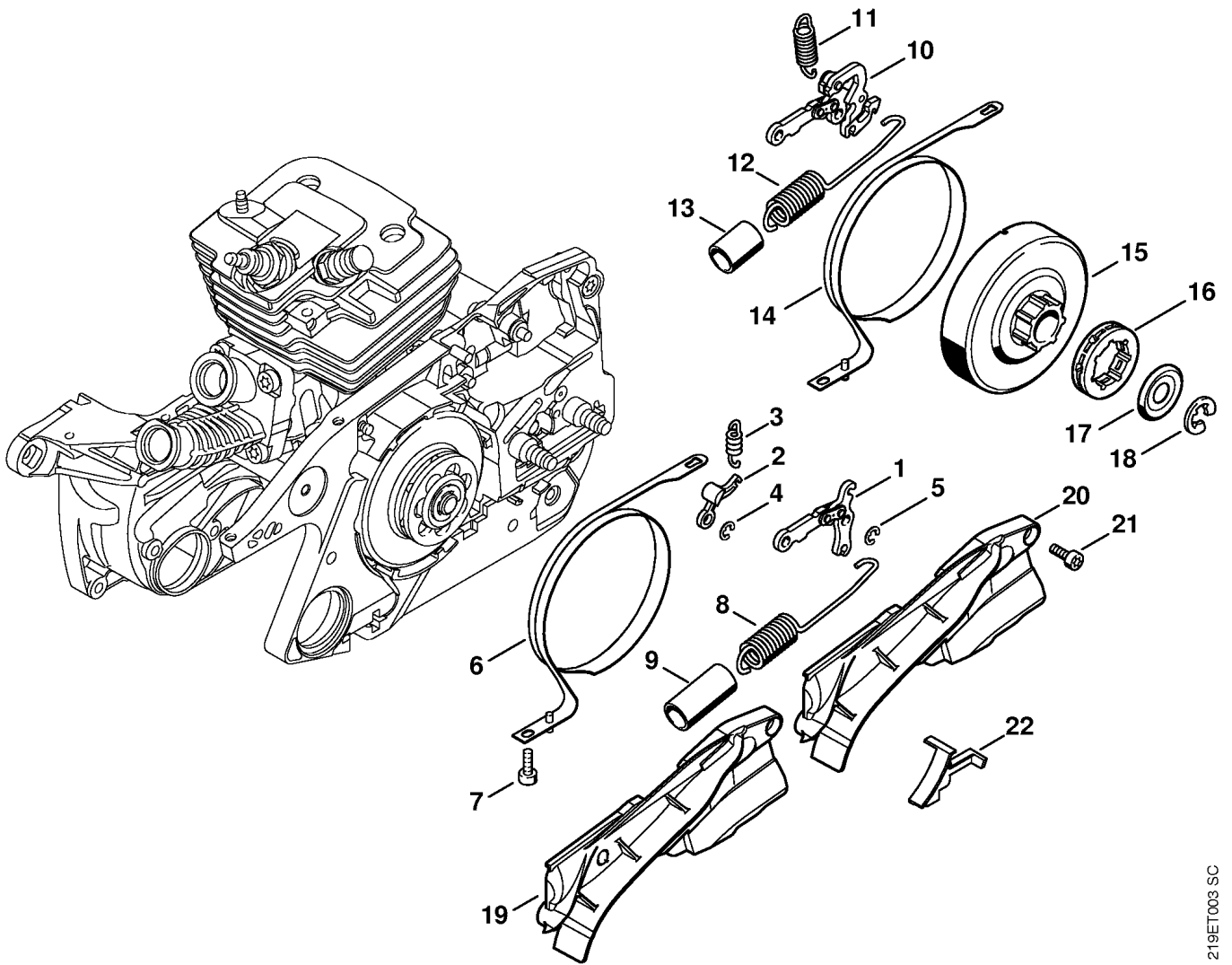

219ET003 SC

Reference	Item number	Qty	Description
1	1138 160 5000	1	Lever (1-6)
2	1121 162 5010	1	Lever
3	0000 997 0628	1	Spring
4	9460 624 0400	1	E-clip 4
5	9460 624 0400	1	E-clip 4 (1-6)
6	1138 160 5400	1	Brake band (1-6)
7	9022 313 0660	1	Spline screw IS-M4x12
8	1138 160 5500	1	Tension spring (1-6)
			□ 9
9	1125 162 8002	1	Hose 20 mm / 13/16" (1-6)
10	1138 160 5001	1	Lever (7,8)
11	1125 162 7905	1	Tension spring (7,8)
12	1138 160 5501	1	Tension spring (7,8)
			□ 13
13	1121 162 8000	1	Hose 12x1x20 mm (7,8)
14	1138 160 5450	1	Brake band (7,8)
			□ 15
15		1	Clutch drum (D) (7,8)
16	0000 642 1223	1	Rim sprocket 3/8" 7T
17	0000 958 1032	1	Washer Ø 27 mm
18	9460 624 0801	1	E-clip 8x1.3
19	1138 021 1105	1	Cover (7,8)
20	1138 021 1100	1	Cover (1-6)
21	9022 313 0660	2	Spline screw IS-M4x12
22	1138 021 1101	1	Cover

(1) MS 441, (2) MS 441-W, (3) MS 441-Z, (4) MS 441-VWZ, (5) MS 441-RVWZ, (6) MS 441-RZ, (7) MS 441 C-Q, (8) MS 441 C-Q Z

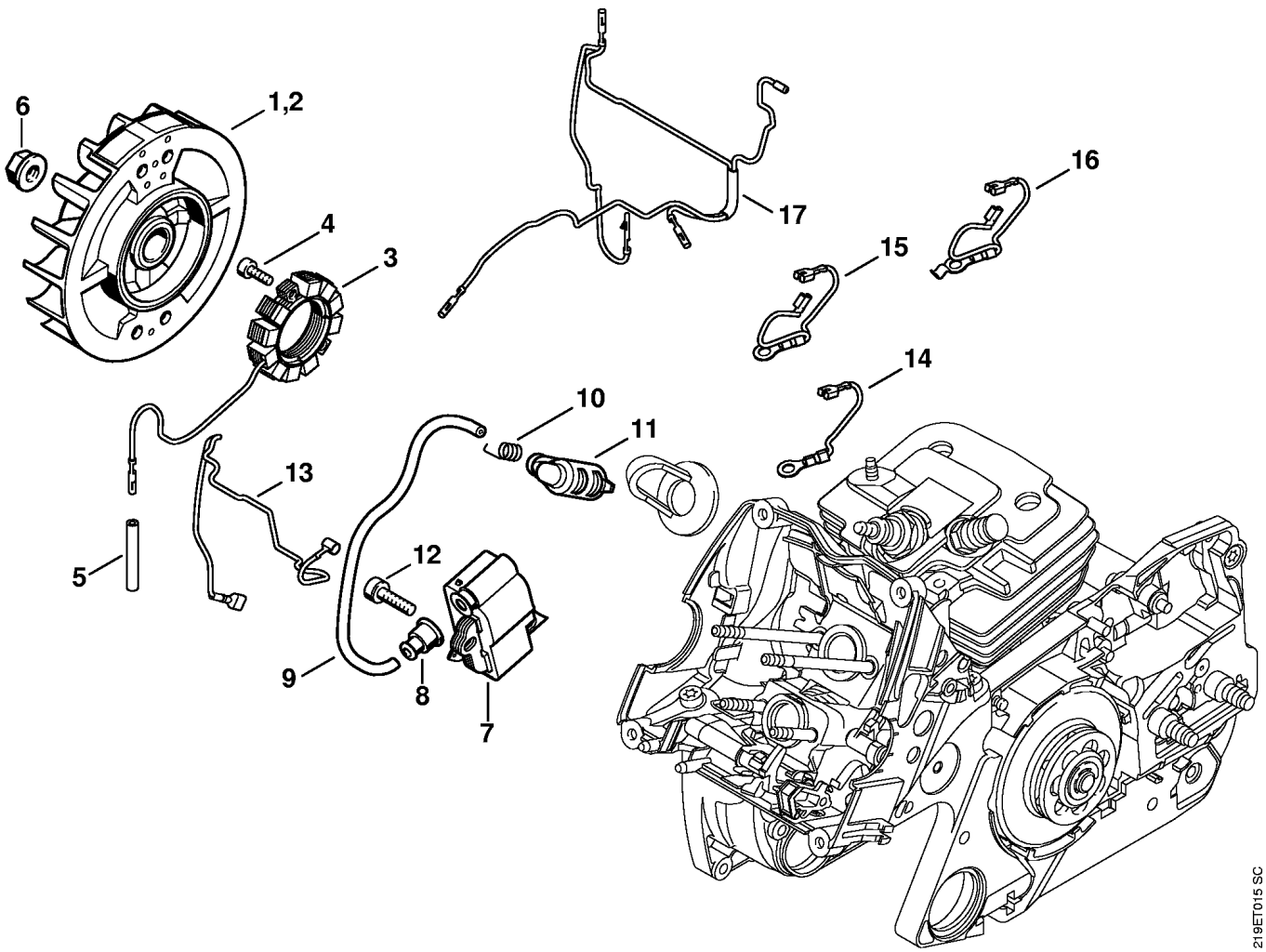

219ET015 SC

Reference	Item number	Qty	Description
1	1138 400 1202	1	Flywheel (1,3,6-8) (25.2005)
2	1138 400 1203	1	Flywheel (2,4,5) (25.2005)
3	1138 404 3501	1	Generator (2,4,5)
4	9022 313 0658	2	Spline screw IS-M4x12 (2,4,5)
5	1121 442 0402	1	Insulating hose 35 mm / 1.4" (2,4,5)
6	0000 955 0802	1	Collar nut M8x1
7	1138 400 1300	1	Ignition module □ 8, 9
8	0000 989 1002	1	Grommet
9		1	Ignition lead 227 mm (D)
	0000 405 0600	1	Ignition lead 1 m (A,B)
	0000 930 2251	1	Ignition lead 10 m (A,B)
10	0000 998 0604	1	Torsion spring
11	1128 405 1000	1	Spark plug boot
12	9022 341 1019	2	Spline screw IS-M5x20
13	1138 440 1100	1	Short circuit wire
14	1138 440 2203	1	Ground wire (1,3,6-8)
15	1138 440 2202	1	Ground wire (2,4,5)
16	* 1138 440 2201	1	Ground wire (2,4,5) (45.2007)
17	1138 440 3004	1	Wiring harness (2,4,5)

(1) MS 441, (2) MS 441-W, (3) MS 441-Z, (4) MS 441-VWZ, (5) MS 441-RVWZ, (6) MS 441-RZ, (7) MS 441 C-Q, (8) MS 441 C-Q Z

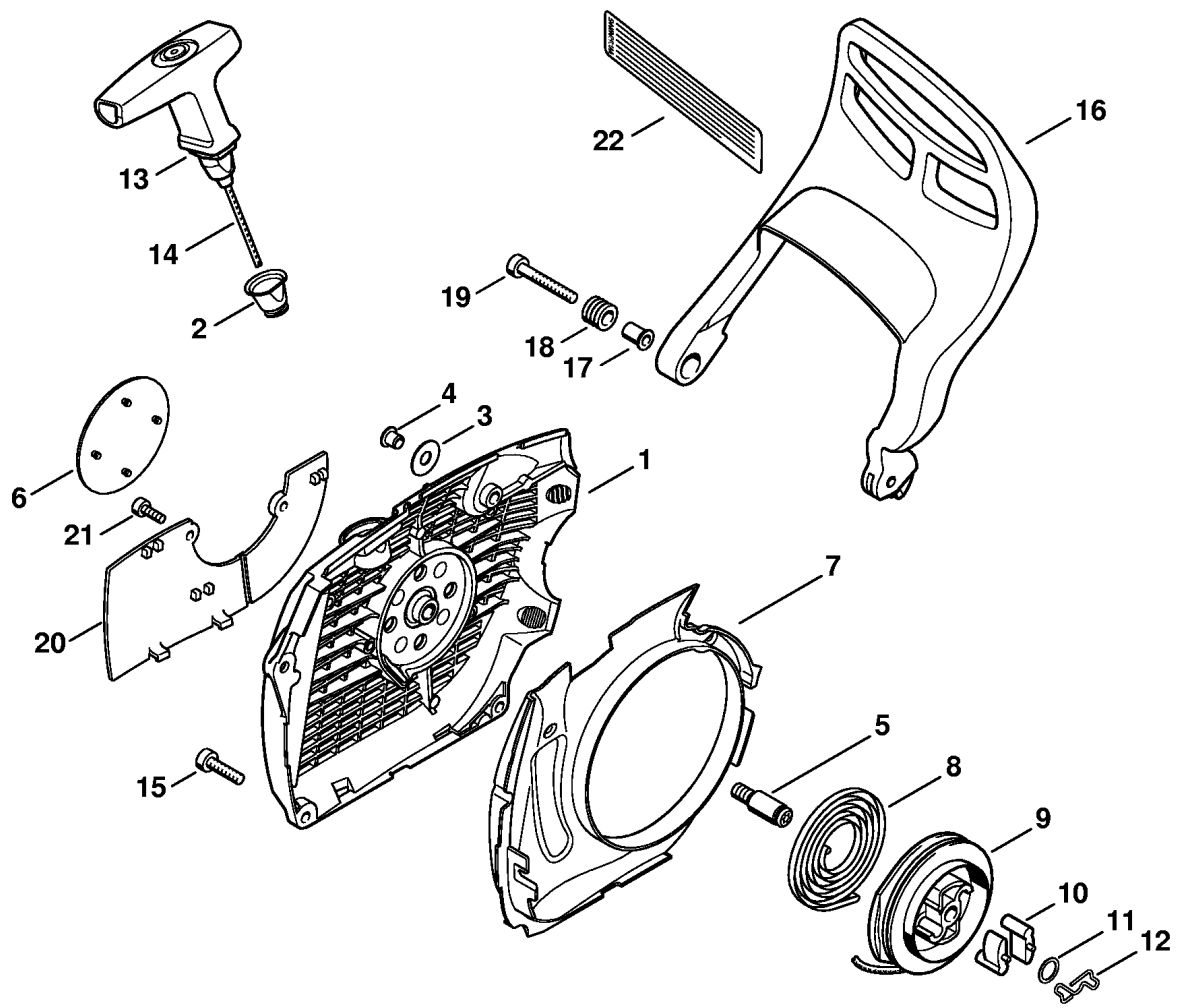

219ET005 SC

Reference	Item number	Qty	Description
	1138 080 2150	1	Fan housing with rewind starter □ 1 - 14
1	1138 080 1800	1	Fan housing □ 2 - 5
2	1110 084 9102	1	Bushing
3	0000 958 0607	1	Washer
4	9416 868 6530	1	Hollow rivet 6.5x0.5x6.8
5	1128 080 6500	1	Axle □ 11
6	1138 967 1500	1	Model plate MS 441 (1-6)
6	1138 967 1501	1	Model plate MS 441 C (7,8)
7	1138 084 7800	1	Segment
8	1135 190 0600	1	Rewind spring
9	1128 195 0400	1	Rope rotor
10	1125 195 7200	2	Pawl
11	0000 958 0923	1	Washer
12	1128 195 3500	1	Spring
13	1128 190 3400	1	Starter grip ElastoStart Ø 3,5 mm □ 14
14	1128 190 2900	1	Starter rope Ø 3.5 mm
	0000 930 2267	1	Starter rope Ø 3.5 mm / 28 pieces (A,B)
15	9022 371 1020	3	Spline screw IS-M5x20
16	1138 790 9101	1	Hand guard □ 17 - 19
17	1124 792 5500	1	Bushing
18	1124 792 5505	1	Bushing
19	9022 341 1080	1	Spline screw IS-M5x35
	1138 007 1000	1	Cover plate kit (B) □ 20, 21
20	1138 084 8200	1	Cover plate (B)
21	9022 313 0660	2	Spline screw IS-M4x12 (B)
22	0000 967 3612	1	Instruction label USA

(1) MS 441, (2) MS 441-W, (3) MS 441-Z, (4) MS 441-VWZ, (5) MS 441-RVWZ, (6) MS 441-RZ, (7) MS 441 C-Q, (8) MS 441 C-Q Z

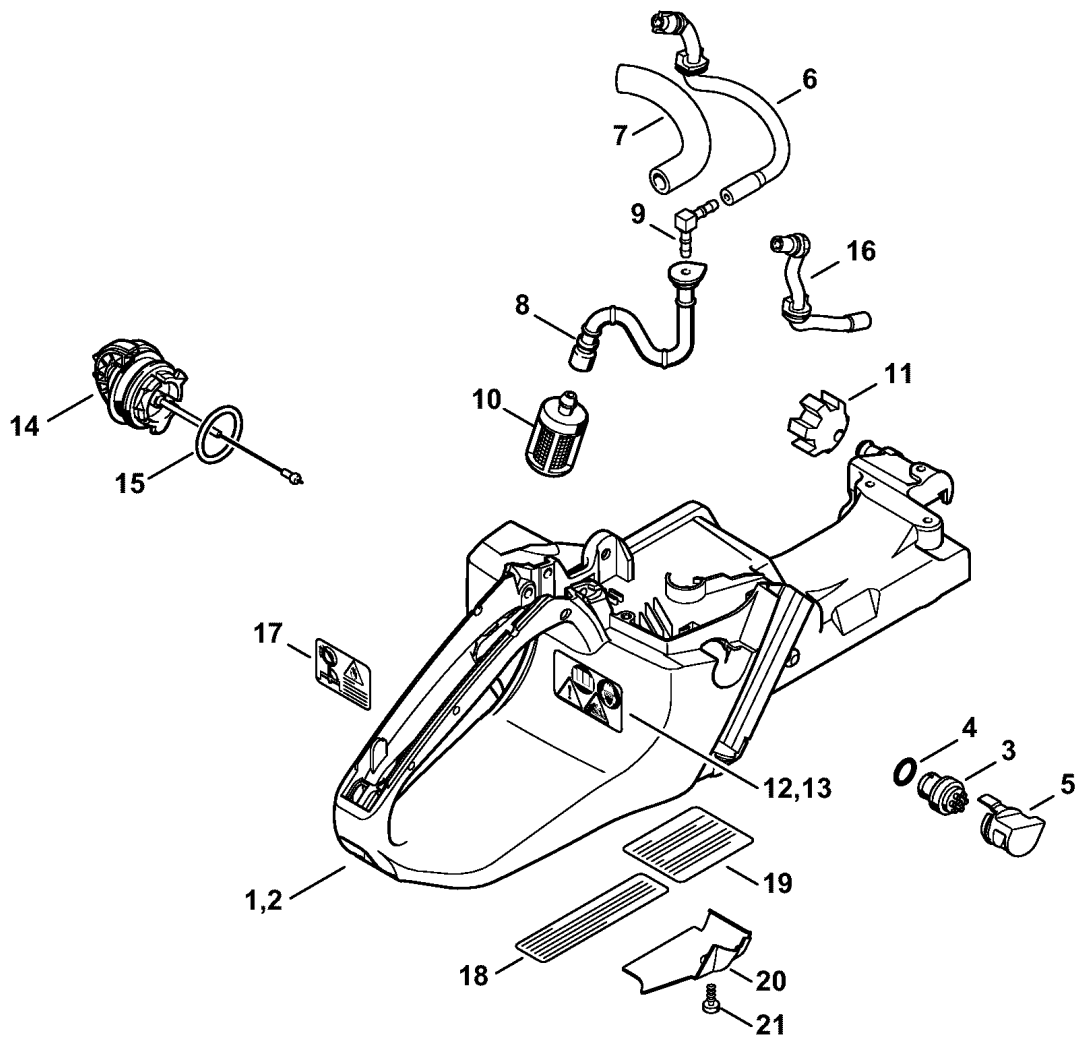

219ET021 SC

Reference	Item number	Qty	Description
1	1138 350 0805	1	Tank housing (1-6) (16.2008) □ 3 - 12, 14, 15
2	1138 350 0806	1	Tank housing (7,8) (16.2008) □ 3 - 11, 13 - 15
3	0000 350 5800	1	Tank vent □ 4
4		1	O-ring 10x2.1 FPM 70 (D)
5	1138 353 7000	1	Cover
	* 1138 350 2750		Fuel hose (16.2008) □ 6 - 8
6	1138 350 2702	1	Fuel hose (16.2008) □ 7
7	0000 937 4070	1	Fuel hose 90 mm / 3 1/2" (16.2008)
8	1138 358 7705	1	Hose (16.2008)
9	1122 353 2600	1	Elbow connector
10	0000 350 3504	1	Pickup body
11	1135 791 2800	1	Annular buffer
12	0000 967 3662	1	Warning pictogram MS (1-6)
13	1125 967 3419	1	Warning pictogram QS (7,8)
14	0000 350 0525	1	Filler cap □ 15
15	9645 948 7734	1	O-ring 25x3.5
16	1138 141 8600	1	Hose
17	0000 967 3798	1	Warning pictogram Filler cap USA, CDN
18	0000 967 3500	1	Instruction label USA
19	1125 967 3418	1	Instruction label (7,8) USA, CDN
20	1138 656 1501	1	Guard USA, CDN, AUS, NZ
21	9074 478 2970	1	Pan head self-tapping screw IS-P4x10 USA, CDN, AUS, NZ

(1) MS 441, (2) MS 441-W, (3) MS 441-Z, (4) MS 441-VWZ, (5) MS 441-RVWZ, (6) MS 441-RZ, (7) MS 441 C-Q, (8) MS 441 C-Q Z



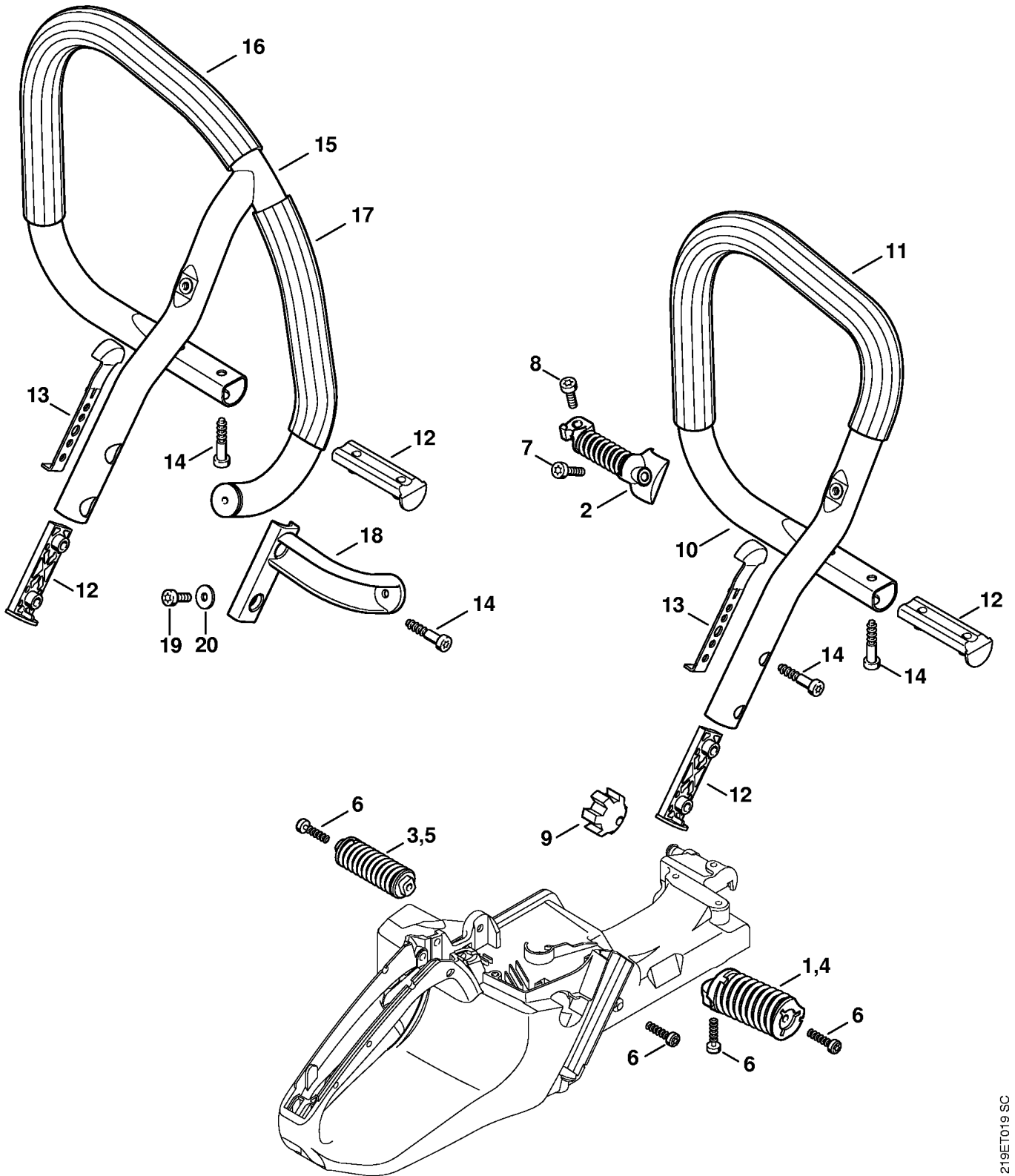

219ET019 SC

Reference	Item number	Qty	Description
	1138 007 1002	1	AV-Spring kit, soft (B) (1,2,7) □ 1 - 3
1	1138 790 8300	1	AV-Spring (1,2,7)
2	1138 790 8311	1	AV-Spring
3	1138 790 8302	1	AV-Spring (1,2,7)
	1138 007 1003	1	AV-Spring kit, hard (B) (3,4-6,8) USA, CDN □ 2, 4, 5
4	1138 790 8310	1	AV-Spring (3,4-6,8) USA, CDN
5	1138 790 8312	1	AV-Spring (3,4-6,8) USA, CDN
6	9074 477 4135	4	Pan head self-tapping screw IS-P5x20
7	9022 341 0980	1	Spline screw IS-M5x16
8	9022 341 0982	1	Spline screw IS-M5x16
9	1135 791 2800	1	Annular buffer
10	1138 790 1700	1	Handlebar (1,3,7,8) □ 11
11		1	Handle hose 470 mm / 18 8/16" (D) (1,3,7,8)
	0000 791 2009	1	Handle hose Ø 19 mm x 5 m / 3/4x197" (A,B) (1,3,7,8)
12	1138 791 5100	2	Stiffener
13	1138 792 9400	1	Limit stop
14	9074 478 4655	4	Pan head self-tapping screw IS-P6x30
15	1138 790 3600	1	Wrap around handlebar (6) □ 16, 17
16		1	Handle hose 390 mm / 15 3/8" (D) (6)
17		1	Handle hose 210 mm / 10 6/8" (D) (6)
	0000 791 2009	1	Handle hose Ø 19 mm x 5 m / 3/4x197" (A,B) (6)
18	1138 791 5500	1	Elbow connector (6)
19	9022 341 0980	1	Spline screw IS-M5x16 (6)
20	9307 021 0120	1	Washer 5.3 (6)

(1) MS 441, (2) MS 441-W, (3) MS 441-Z, (4) MS 441-VWZ, (5) MS 441-RVWZ, (6) MS 441-RZ, (7) MS 441 C-Q, (8) MS 441 C-Q Z

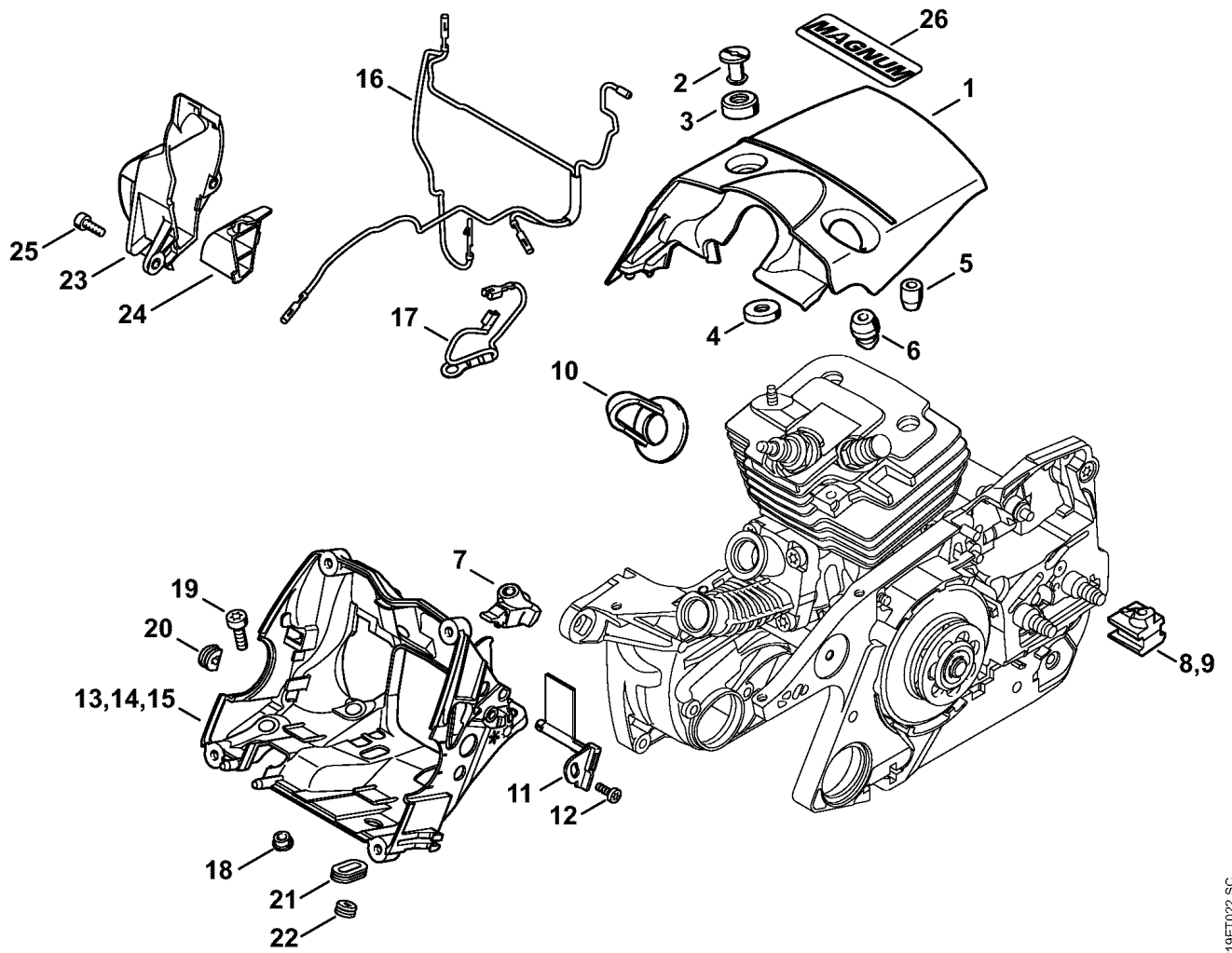

219ET022 SC

Drawing J Shroud, Housing

Reference	Item number	Qty	Description
	1138 080 1651	1	Shroud □ 1 - 8
	* 1138 080 1650	1	Shroud (13.2009) □ 1 - 5, 8
1	1138 084 0902	1	Shroud (13.2009)
2	1121 084 7000	1	Slotted nut
	1138 007 1005	1	Set of grommets □ 3 - 8
3	1121 084 6901	1	Insulator
4	1135 028 1002	1	Grommet
5	1121 084 7100	1	Cap
6	1138 028 1001	1	Grommet
7	1138 028 1000	1	Grommet
8	1138 028 1004	1	Grommet
9	* 1138 028 1002	1	Grommet (13.2009)
10	1128 084 1400	1	Cover
11	1138 084 4101	1	Shutter
12	9074 478 2967	1	Pan head self-tapping screw IS-P4x10
13	1138 120 3502	1	Housing (1,3,6-8) □ 18
14	1138 120 3503	1	Housing (2,4,5) □ 18
15	* 1138 120 3504	1	Housing (2,4,5) (45.2007) □ 16 - 18
16	1138 440 3004	1	Wiring harness (2,4,5)
17	1138 440 2202	1	Ground wire (2,4,5)
18		4	Bushing (D)
19	9022 341 0980	4	Spline screw IS-M5x16
20	0000 989 0507	1	Grommet
21	1138 182 0701	1	Grommet
22	0000 989 0808	1	Grommet (2,4,5)
23	1138 140 7800	1	Pre-separator
24	1138 141 7600	1	Duct base
25	9022 313 0660	2	Spline screw IS-M4x12
26	0000 967 1593	1	Model plate Magnum (3-6,8) USA, CDN

(1) MS 441, (2) MS 441-W, (3) MS 441-Z, (4) MS 441-VWZ, (5) MS 441-RVWZ, (6) MS 441-RZ, (7) MS 441 C-Q, (8) MS 441 C-Q Z

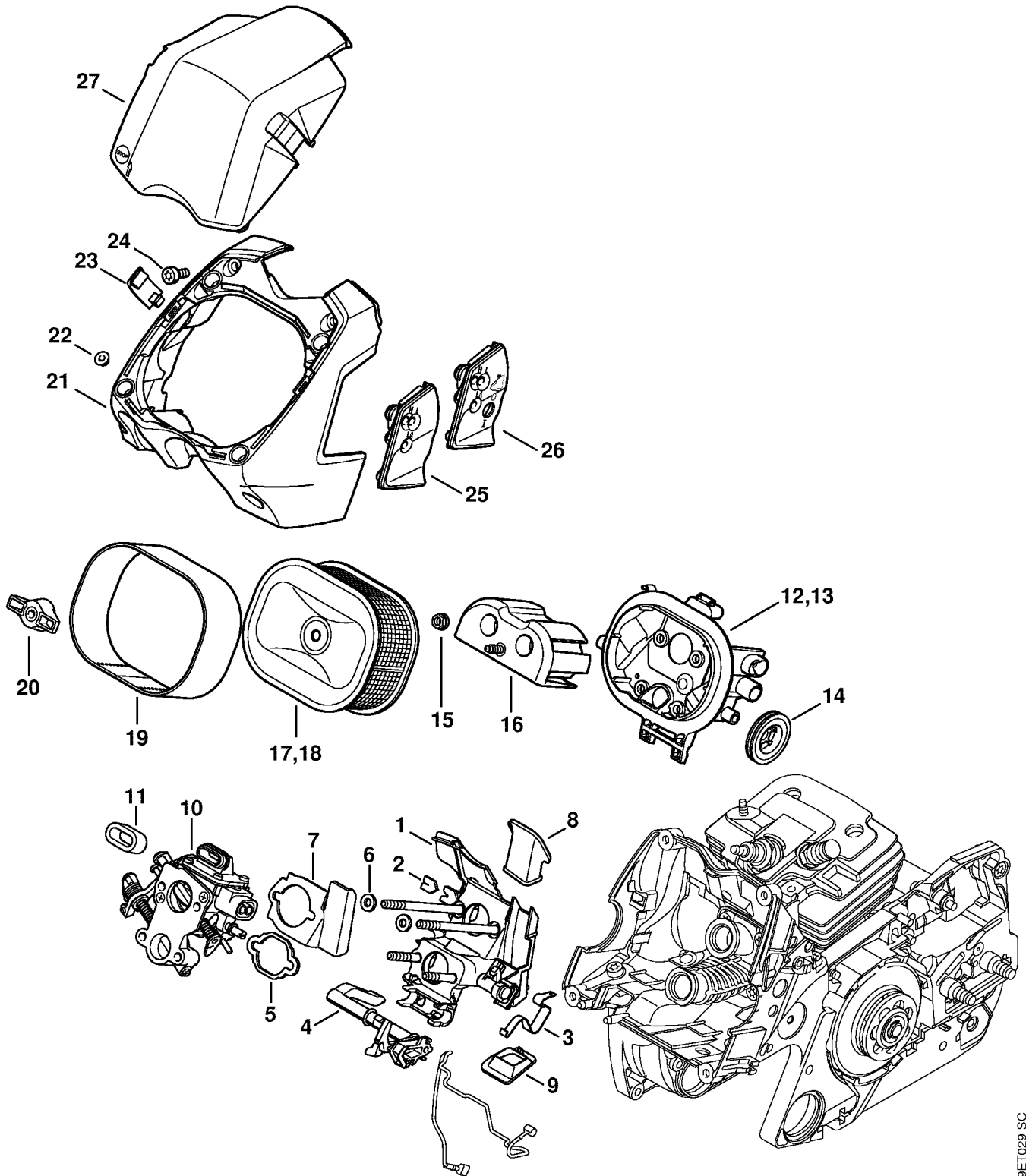

219ET029 SC

Reference	Item number	Qty	Description
1	1138 120 0905	1	Carburetor bracket □ 2, 3
2	1138 122 3100	1	Felt
3	1138 442 1600	1	Contact spring
4	1138 182 0900	1	Switch shaft
5	1138 121 8600	1	Washer
6	0000 958 0513	2	Washer
7	1138 122 9500	1	Preheater plate
8	1138 121 2600	1	Air guide inlet
9	1138 121 4100	1	Air guide outlet
10	1138 120 0600	1	Carburetor HD-41B
11	1124 121 9100	1	Bushing
12	1138 141 0900	1	Filter base (1,2,3,6-8)
13	1138 141 0901	1	Filter base (4,5)
14	1138 120 8200	2	Buffer
15	9216 261 0700	4	Hexagon nut M5
16	1138 120 4100	1	Baffle
17	0000 120 1653	1	Air filter, wire mesh (B)
18	0000 120 1654	1	Air filter HD □ 19
19	0000 141 0300	1	Prefilter
20	1138 140 9500	1	Slotted nut
21	1138 140 1501	1	Inner housing □ 22, 23
22	1138 141 9600	4	Rubber buffer
23	1138 140 1600	2	Snap closure
24	9022 341 0960	4	Spline screw IS-M5x12
25	1138 123 7500	1	Grommet (1,3,6-8)
26	1138 123 7501	1	Grommet (2,4,5)
27	1138 141 1001	1	Carburetor box cover

(1) MS 441, (2) MS 441-W, (3) MS 441-Z, (4) MS 441-VWZ, (5) MS 441-RVWZ, (6) MS 441-RZ, (7) MS 441 C-Q, (8) MS 441 C-Q Z



Reference	Item number	Qty	Description
1	1138 182 1000	1	Throttle trigger (1-6)
2	1138 182 4500	1	Torsion spring (1-6)
3	9371 470 2640	2	Cylindrical pin 5x24
4	1138 180 1104	1	Throttle cable (1-6) (45.2008)
5	1138 180 1105	1	Throttle cable (7,8) (45.2008)
			□ 6
6	9074 478 2967	1	Pan head self-tapping screw IS-P4x10 (7,8)
7	1138 182 0800	1	Trigger interlock (1-6)
8	1138 182 2700	1	Lever
9	1138 791 0600	1	Handle molding (1-6)
10	1138 182 0900	1	Switch shaft
11	1138 442 1600	1	Contact spring
12	1138 180 1500	1	Throttle trigger (7,8)
13	1138 182 4501	1	Torsion spring (7,8)
14	1125 180 1703	1	Trigger interlock (7,8)
			□ 15
15	1125 182 4502	1	Torsion spring (7,8)
16	9517 003 0650	2	Cylindrical roller 3x25.8 (7,8)
17	1125 180 1405	1	Trigger switch (7,8)
18	1138 160 2501	1	Brake cable (7,8)
19	9074 478 2967	1	Pan head self-tapping screw IS-P4x10
20	1138 791 0601	1	Handle molding (7,8)

(1) MS 441, (2) MS 441-W, (3) MS 441-Z, (4) MS 441-VWZ, (5) MS 441-RVWZ, (6) MS 441-RZ, (7) MS 441 C-Q, (8) MS 441 C-Q Z



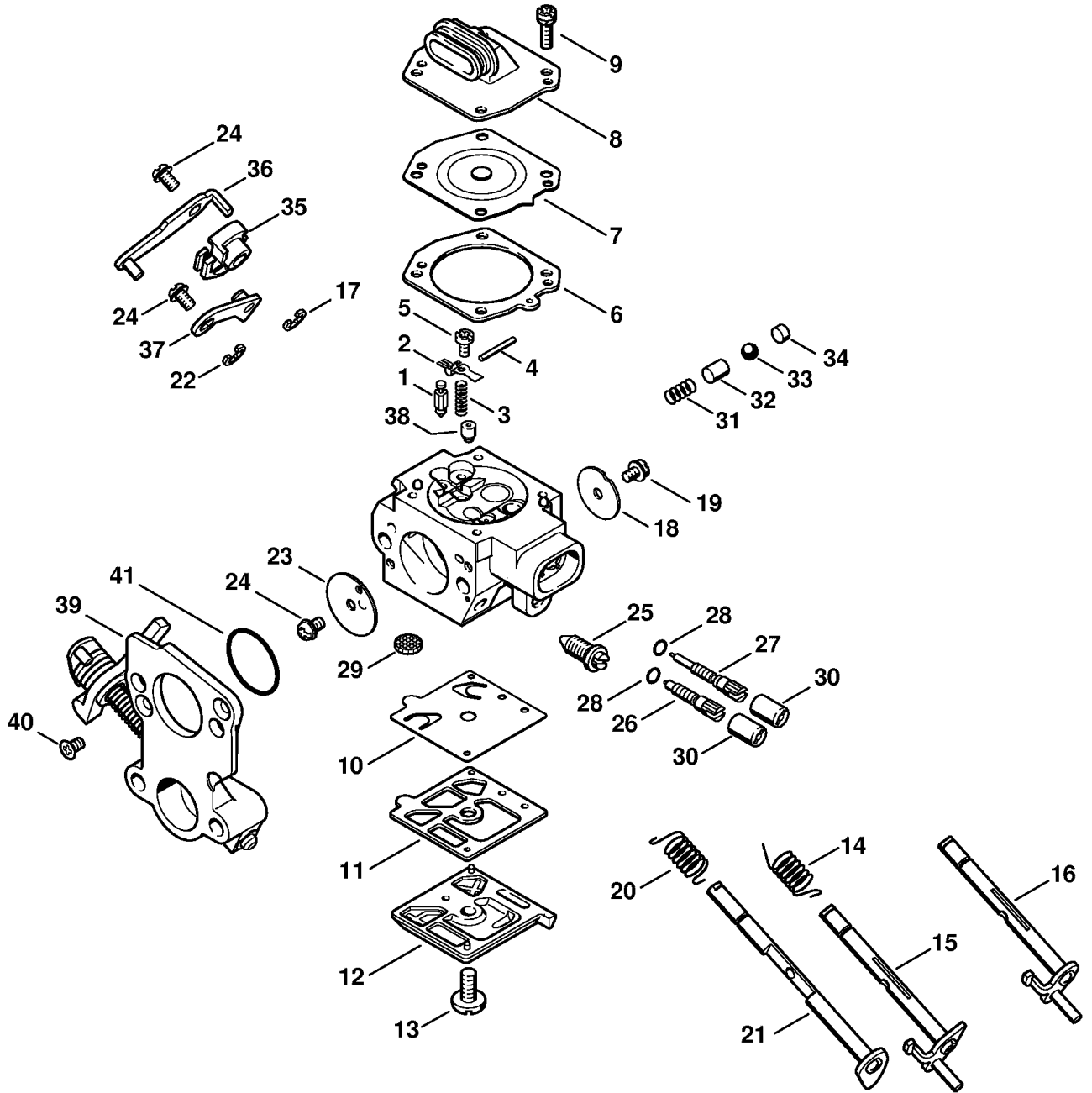

219ET014 SC

Reference	Item number	Qty	Description
	1138 120 0600	1	Carburetor HD-41B □ 1 - 15, 17 - 41
1	4116 121 5100	1	Inlet needle
2	4116 121 5000	1	Inlet control lever
3	1128 122 3002	1	Spring
4	1113 121 9200	1	Spindle
5	1114 122 7400	1	Round head screw
6	1128 129 0906	1	Gasket
7	4116 121 4700	1	Metering diaphragm
8	1128 121 0801	1	End cover
9	1138 122 7100	4	Screw
10	4116 121 4800	1	Pump diaphragm
11	4116 129 0902	1	Gasket
12	4203 121 0800	1	End cover
13	1114 122 7100	1	Screw
14	1127 122 3205	1	Torsion spring
15	1138 120 7101	1	Throttle shaft with lever
16	* 1138 120 7100	1	Throttle shaft with lever (25.2007)
17	1117 122 9000	1	E-clip
18	1138 121 3300	1	Throttle shutter
19	1115 122 7400	1	Round head screw
20	1138 122 3200	1	Torsion spring
21	1138 120 7200	1	Choke shaft with lever
22	1123 122 9000	1	E-clip
23	4116 121 2900	1	Choke shutter
24	1121 122 7102	3	Round head screw
25	1121 122 6201	1	Idle speed adjustment screw
26	1128 122 6703	1	High speed adjustment screw □ 28
27	1128 122 6806	1	Low speed adjustment screw □ 28
28	4203 122 3600	1	Sealing ring
29	1114 121 7800	1	Strainer
30	4203 121 2700	2	Cap

(1) MS 441, (2) MS 441-W, (3) MS 441-Z, (4) MS 441-VWZ, (5) MS 441-RVWZ, (6) MS 441-RZ, (7) MS 441 C-Q, (8) MS 441 C-Q Z

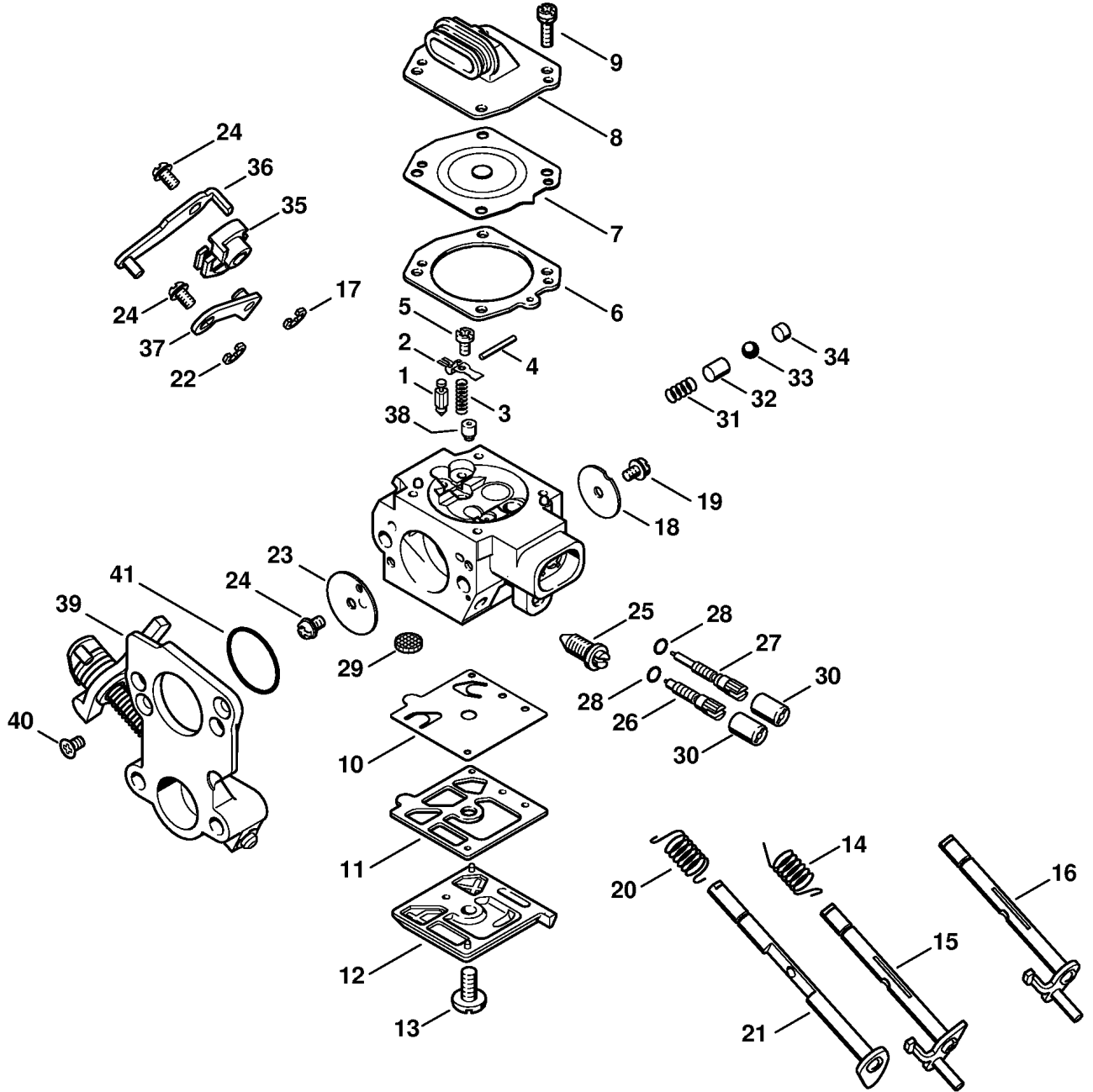

219ET014 SC

---

Reference	Item number	Qty	Description
	1133 120 9700	1	Pump piston kit □ 31 - 34
31		1	Spring (D)
32		1	Pump piston (D)
33		1	Ball (D)
34		1	Plug (D)
35	1138 121 0000	1	Throttle cable retainer
36	1138 120 8300	1	Lever
37	1138 120 8301	1	Lever
38	1122 121 5604	1	Fixed jet 0.64
39	1138 007 1004	1	Air valve housing □ 40, 41
40	1138 122 7900	2	Countersunk screw
41	1138 129 3000	1	Sealing ring
	1128 007 1066	1	Set of carburetor parts □ 1 - 3, 6, 7, 10, 11, 29

(1) MS 441, (2) MS 441-W, (3) MS 441-Z, (4) MS 441-VWZ, (5) MS 441-RVWZ, (6) MS 441-RZ, (7) MS 441 C-Q,  
(8) MS 441 C-Q Z

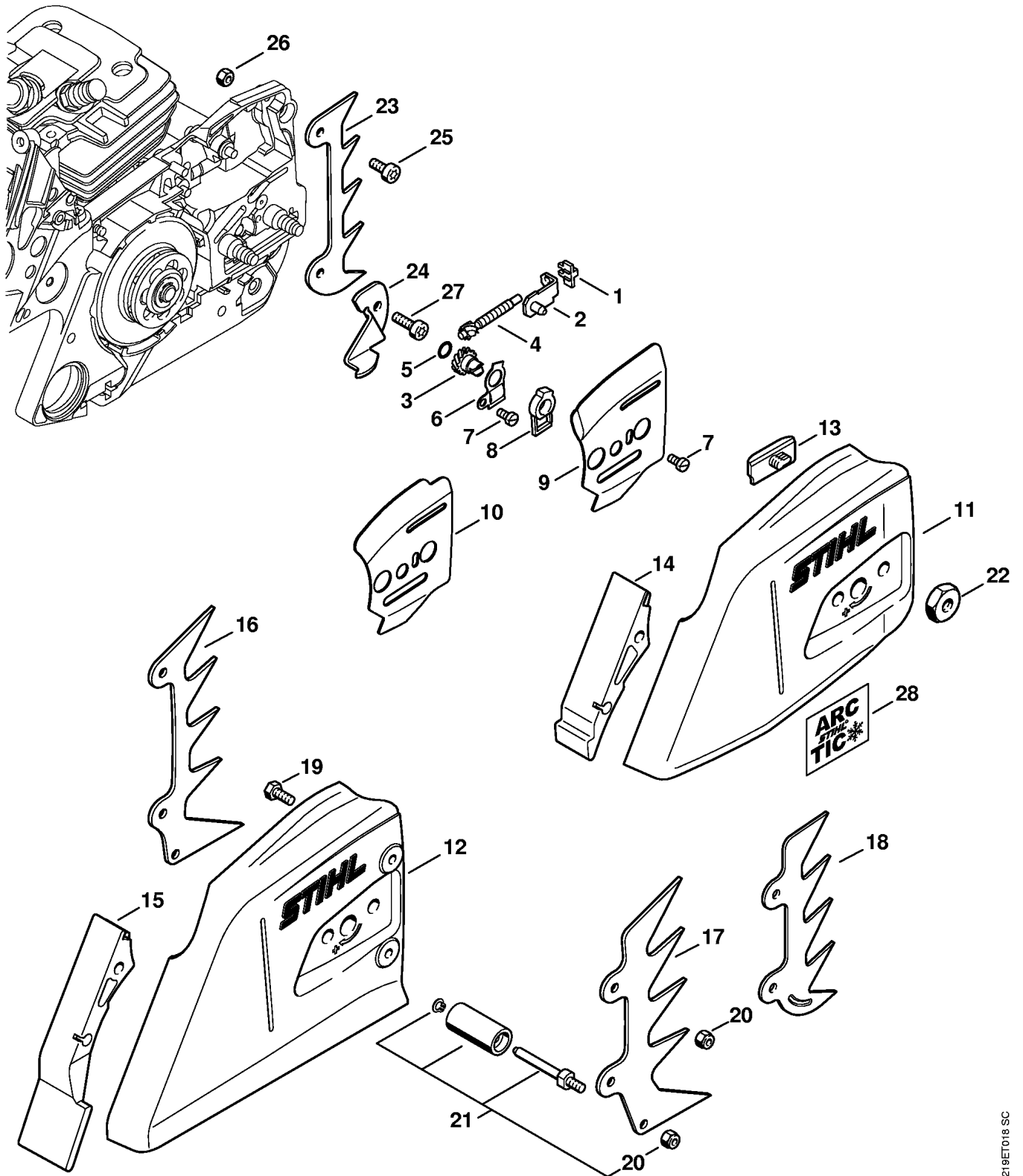

219ET018 SC

Reference	Item number	Qty	Description
1	1125 664 1400	1	Thrust pad
2	1125 640 1900	1	Tensioner slide
	1125 007 1021	1	Spur gear / chain adjusting screw kit □ 3 - 5
3		1	Spur gear (D)
4		1	Adjusting screw (D)
5	9646 945 0490	1	O-ring 7x1.5
6	1122 664 2200	1	Cover plate
7	9041 216 0630	2	Pan head screw M4x8
8	1122 664 4500	1	Support
9	1122 664 1000	1	Inner side plate 0.5 mm (1-4)
9	1128 664 1001	1	Inner side plate 0.9 mm (5,6)
10	1138 664 1000	1	Inner side plate (7,8)
11	1135 640 1703	1	Chain sprocket cover (1-4,7,8) □ 13, 14
	1138 640 1700	1	Chain sprocket cover (5,6) □ 12, 13, 15, 17, 19 - 21
12	1138 648 0400	1	Chain sprocket cover (5,6)
13	1121 648 6610	2	Bumper strip
14	1135 656 1500	1	Guard (1-4,7,8)
15	1138 656 1500	1	Guard (5,6)
16	1122 664 0506	1	Bumper spike (5,6)
17	1122 664 0501	1	Bumper spike (5,6)
18	0000 660 0850	1	Bumper spike (B) □ 19, 20
19	9008 319 0960	2	Hexagon head screw M5x12 (5,6)
20	9214 320 0700	3	Lock nut M5 (5,6)
21	1122 650 7700	1	Chain catcher (5,6)
22	0000 955 0801	2	Hexagon nut M8
23	1128 664 0500	1	Bumper spike (1-4,7,8)
24	1122 656 7700	1	Chain catcher (1-4,7,8)
25	9022 341 0960	1	Spline screw IS-M5x12
26	9214 320 0700	1	Lock nut M5
27	9022 341 1019	1	Spline screw IS-M5x20
28	0000 967 3714	1	Instruction label ARCTIC (4,5) USA, CDN

(1) MS 441, (2) MS 441-W, (3) MS 441-Z, (4) MS 441-VWZ, (5) MS 441-RVWZ, (6) MS 441-RZ, (7) MS 441 C-Q, (8) MS 441 C-Q Z

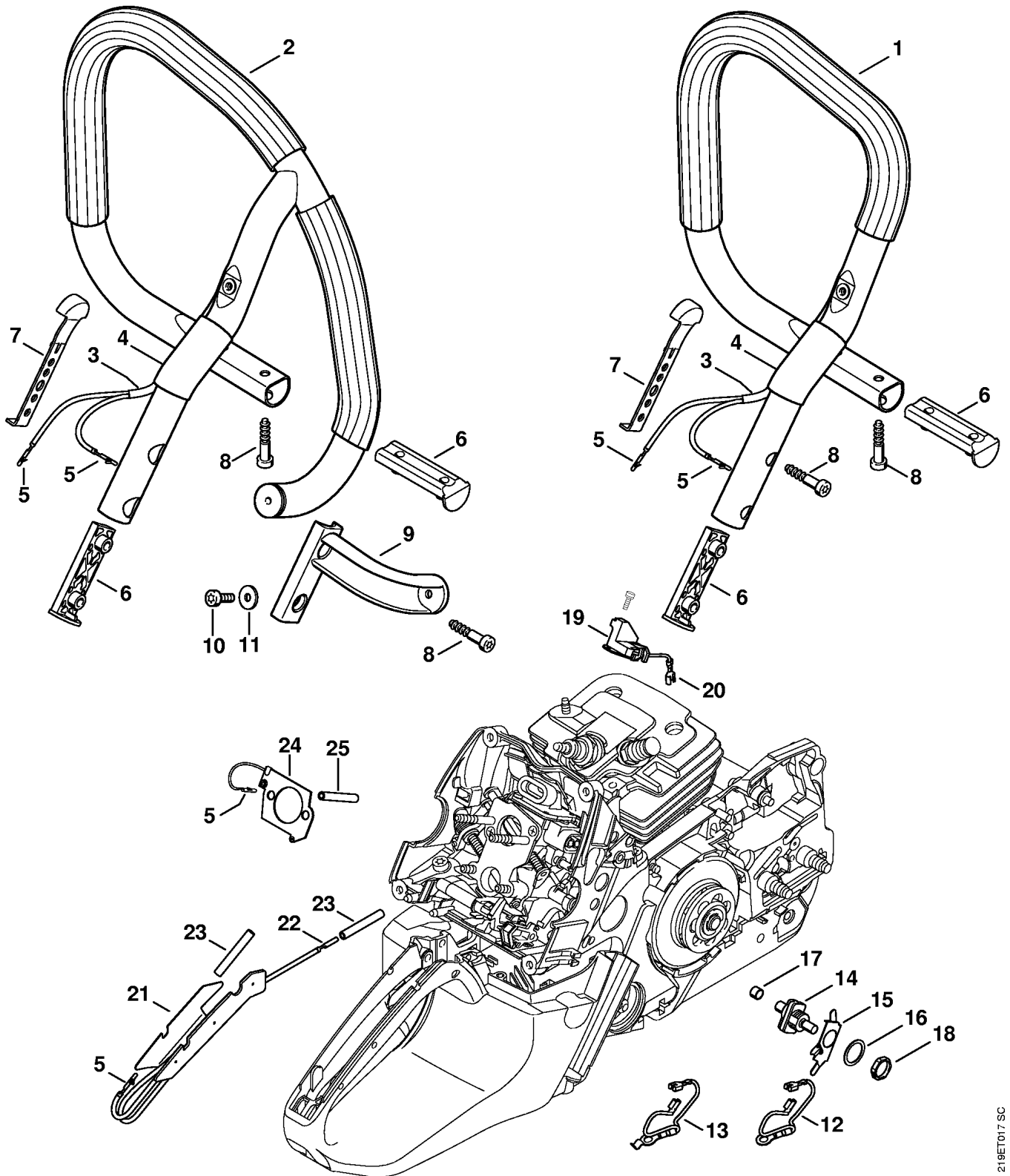

219ET017 SC

Reference	Item number	Qty	Description
1	1138 790 1703	1	Handlebar (2,4) □ 3, 4, 5
2	1138 790 3603	1	Wrap around handlebar (5) □ 3, 4, 5
3	1138 442 0401	1	Insulating hose (2,4,5)
4	1138 442 0400	1	Insulating hose (2,4,5)
5	1118 431 6600	1	Terminal pin (2,4,5)
6	1138 791 5100	2	Stiffener (2,4,5)
7	1138 792 9400	1	Limit stop (2,4,5)
8	9074 478 4655	4	Pan head self-tapping screw IS-P6x30 (2,4,5)
9	1138 791 5500	1	Elbow connector (5)
10	9022 341 0980	1	Spline screw IS-M5x16 (5)
11	9307 021 0120	1	Washer 5.3 (5)
12	1138 440 2202	1	Ground wire (2,4,5)
13	* 1138 440 2201	1	Ground wire (2,4,5) (45.2007)
14	1138 430 0502	1	Switch (2,4,5)
15	1138 431 2700	1	Twin connector tag (2,4,5)
16	0000 958 1511	1	Washer (2,4,5)
17	1138 448 1202	1	Lead retainer (2,4,5)
18	1128 432 2200	1	Hexagon nut (2,4,5)
19	1138 430 0501	1	Switch (4,5) □ 20
20	0751 030 8953	1	Terminal socket 4.8-1 (4,5)
21	1138 430 6002	1	Heating element (2,4,5) □ 5, 22, 23
22	1118 431 6700	1	Terminal socket (2,4,5)
23	1121 442 0402	2	Insulating hose 35 mm / 1.4" (2,4,5)
24	1138 434 5100	1	Heating element (4,5)
25	1121 442 0402	1	Insulating hose 35 mm / 1.4" (4,5)

(1) MS 441, (2) MS 441-W, (3) MS 441-Z, (4) MS 441-VWZ, (5) MS 441-RVWZ, (6) MS 441-RZ, (7) MS 441 C-Q, (8) MS 441 C-Q Z



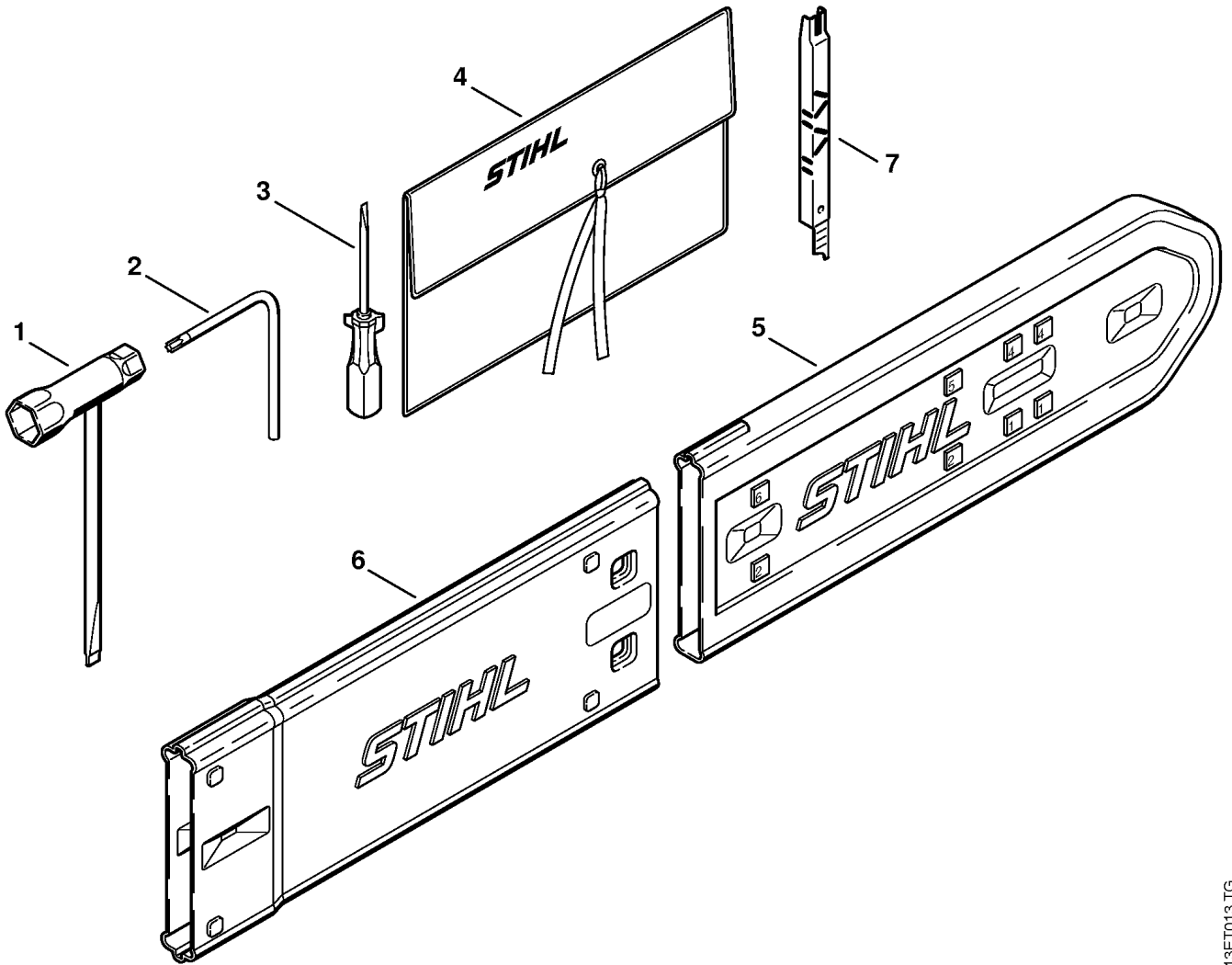

213ET013 TG

---

Reference	Item number	Qty	Description
	1121 890 1400	1	Tool kit □ 1 - 4
1	1129 890 3401	1	Combination wrench
2	0812 370 1000	1	Screwdriver T27x120x70
3	0000 890 2300	1	Screwdriver
4	0000 891 0801	1	Tool roll
5	0000 792 9129	1	Chain scabbard
6	0000 792 9132	1	Chain scabbard extension up to 63 cm (B)
7	1110 893 4000	1	Filing gauge (B)

(1) MS 441, (2) MS 441-W, (3) MS 441-Z, (4) MS 441-VWZ, (5) MS 441-RVWZ, (6) MS 441-RZ, (7) MS 441 C-Q,  
(8) MS 441 C-Q Z